

TECHNICAL DATA

SECTION: Centrifugal

ISSUED: July 2002

Onga manufacture the Award winning onga Hi-flo range of 400 series centrifugal pumps from moulded materials giving superior resistance to corrosion. They are strong, durable and built to cover a wide range of domestic, rural and semi-commercial applications.

Typical Applications:

- Hose down
- General water Transfer
- Tank filling
- Fountains and Waterfalls
- Spear Point
- Hydroponics
- Sprinklers and Garden watering



FEATURES

- Award winning high flow impeller
- Moulded construction
- Cool Running Totally Enclosed Fan Cooled Motor (TEFC)
- Inbuilt Thermal overload
- Wide Model Selection

BENEFITS

- Efficient design produces greater flow whilst maintaining low power consumption.
- Moulded from high-grade material, this construction has proven to be very stable against a wide range of corrosive materials.
- Provides greater resistance to vermin, water ingress and cooler operation giving improved reliability and a longer life.
- Protects the motor under normal operating conditions. Automatic reset allows the pump to continue if suitable conditions are available.
- With Flow Rates up to 270 lpm and head pressure to 26 metres, the 400 series gives you a wide range of models to choose from making selection of the correct pump easy.

Pump Performance Table (50Hz):

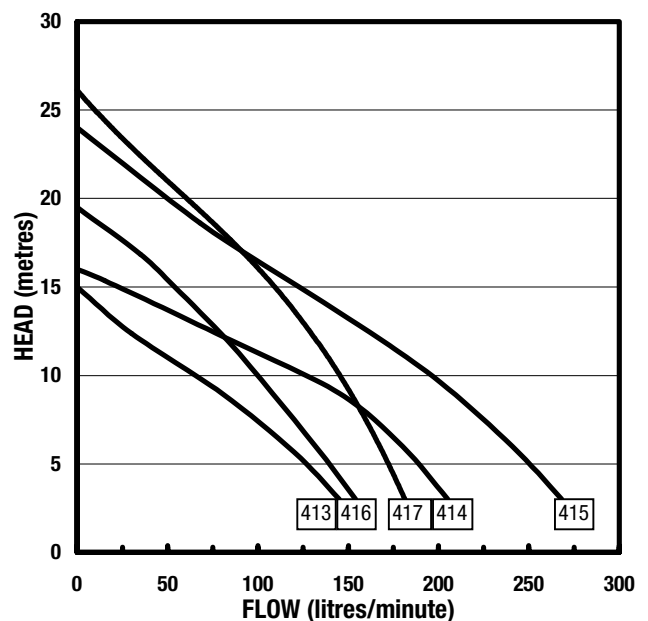
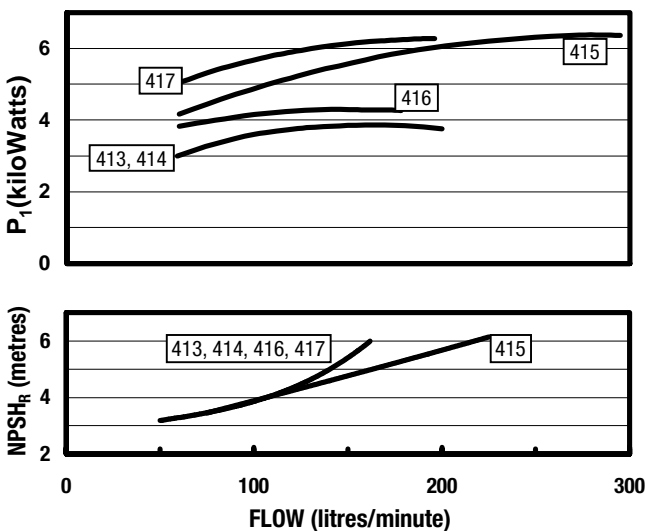

Disclaimers:

Every endeavour has been made to publish the correct details in this data sheet. No responsibility will be taken for errors, omissions or changes in product specifications. All performance data taken at sea level.

TECHNICAL DATA

SECTION: Centrifugal

ISSUED: July 2002

Operating Conditions:

Suitable for pumping clean non-aggressive liquids without solids or fibres in suspension

Fluid: Water*
 Maximum Working Pressure: 410 kPa
 Water Temperature Range: 1°C-70°C*
 Ambient Temperature: 55°C Maximum

*For liquids outside this range please contact your local onga office for product suitability.

Motor:

Type: TEFC 2 Pole
 Continuously Rated
 Nominal Speed: 2900 rpm
 IP Rating: IP55
 Insulation Class: Class B
 Temperature Rise: Class B
 Thermal Overload: Inbuilt Auto Reset
 Frequency: 50Hz*
 Voltage: 230-240*
 Bearing Type: Deep Groove Ball Bearing with double contact Lip Seal
 Bearing Temp. Rating: 150°C

*Some models also available in 110v and 60Hz, check your local onga office for price and availability.

Materials:

Component	Material
Pump Casing:	20% Glass Filled ABS
Impeller:	20% Glass Filled Polycarbonate
Baffle:	20% Glass Filled ABS
Diffuser:	Noryl
Priming Cap:	Polypropylene
Shaft Sleeve:	Nylon
Motor Shaft:	Mild Steel
End Shield:	Die Cast Aluminium Powder Coated
O-ring's:	Nitrile
Mechanical seal, 1/2" Type 6:	
Flexible Bellows:	Nitrile
Stationary Face:	Ceramic
Rotating Face:	Carbon
Spring:	304 Stainless Steel

Line Drawing:

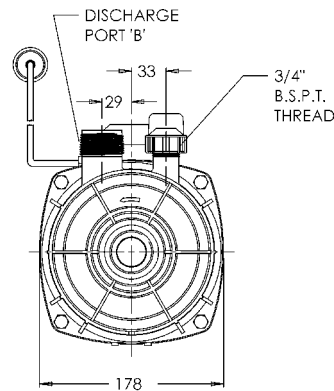
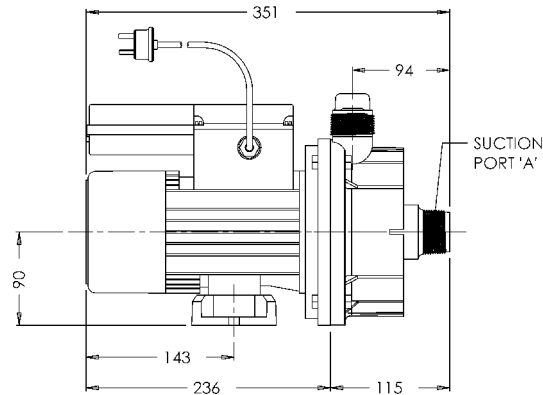

Pump Dimension Table:

Pump Model	Suction Port A (BSP Male)	Discharge Port B (BSP Male)	Pump Weight (kg)	Packed Weight (kg)	Carton Dimensions LxWxH
413	1"	1"	7.3	8.1	373x188x256
414	1 1/4"	1 1/4"	8	9.6	373x188x256
415	1 1/4"	1 1/4"	9.7	10.5	373x188x256
416	1"	1"	8	9.6	373x188x256
417	1"	1"	9.6	10.4	373x188x256

Note: unless otherwise specified, all dimensions in mm. Fixing slots accept 8mm fasteners

Motor Data:

Pump Model	Motor kW (hp)	Supply Voltage	Phase	Full Current (A)	Locked Rotor Current (A)	Output Power P ₂ (W)	Capacitor mfd	Supply Cord Length (m)
413	.4 (1/2)	240	1	2.5	10	375	12	2
414	.55 (3/4)	240	1	2.5	10	375	12	2
415	.75 (1)	240	1	4.3	15	700	20	2
416	.55 (3/4)	240	1	2.6	10	390	12	2
417	.75 (1)	240	1	4.1	15	670	20	2